

Adding Power to Existing Bus

The DC/DC converter in Figure 1 can increase an existing 5 volt power supply's current output by as much as 5 amps. The converter contributes load current in a fixed ratio to that from the main supply, as determined by the sense-resistor ratio: $I_{BOOST} / I_{MAIN} = R_M / R_B$. I_{MAIN} is the main supply's rated maximum current and I_{BOOST} is the maximum supplemental current required. This circuit is useful when add-on options cause a system's current drain to exceed the existing supply's capacity. In operation, op amp IC1 adjusts the DC/DC converter's output voltage until the voltage drops across R_B and R_M are equal. The two 2.2k ohm/0.1 μ F networks provide frequency compensation for the op amp and set the control-loop bandwidth to about 1 kHz. Note that the converter can accept 40 volts, but you must limit supply voltage to the op amp to about 30 volts maximum.

It should be noted that the main supply will lose control of the load voltage when I_{MAIN} approaches zero. Under this light-load condition, the op amp's input offset voltage can force the converter to drive current through the sense resistors. You can prevent this rise by adding a minimum-load resistor or by introducing an offset-adjust circuit for the op amp. This power-boost technique is suitable for supplies without remote-sense connections, but the voltage drop across R_M will subtract from the load voltage. Accordingly, for such applications R_M should be as small as possible.

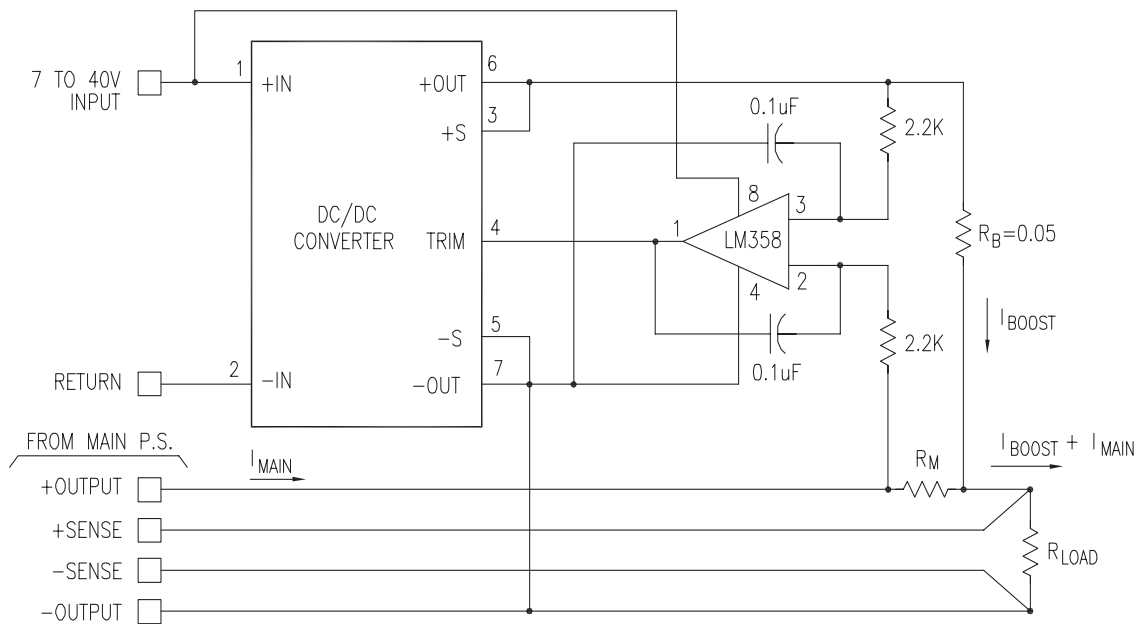

Figure 1.
You can supplement an existing power supply by adding a DC/DC converter and op amp as shown.
The converter adds as much as 5 amps to the load.

