



# 25-30 Watt KMW Single and Dual Series



- Efficiency up to 89%
- 1500VDC Isolation
- MTBF > 1,000,000 Hours
- 4:1 Input
- Six-Sided Shielding
- Remote On/Off
- Output Trim
- UL60950 Approved
- RoHS Compliant



Model Number	Voltage			Current				Reflected Ripple	Input Overvoltage Protection (1000ms)	Over Voltage Protection	Efficiency	Capacitive Load
	Input		Output	Input		Output						
	Nom. (VDC)	Range (VDC)	(VDC)	@ No Load (mA)	@ Max Load (mA)	Min (mA)	Max (mA)					
KMW18H24S3R3	24	10 - 40	3.3	20	922	400	5500	50	50	3.9	82	10000 $\mu$ F
KMW25H24S5	24	10 - 40	5	20	1225	350	5000	50	50	6.8	85	10000 $\mu$ F
KMW30H24S12	24	10 - 40	12	20	1404	166	2500	50	50	15	89	1000 $\mu$ F
KMW30H24S15	24	10 - 40	15	20	1404	133	2000	50	50	18	89	1000 $\mu$ F
KMW30H24D12	24	10 - 40	$\pm 12$	20	1404	$\pm 83$	$\pm 1250$	50	50	$\pm 15$	89	330 $\mu$ F
KMW30H24D15	24	10 - 40	$\pm 15$	20	1404	$\pm 65$	$\pm 1000$	50	50	$\pm 18$	89	330 $\mu$ F
KMW18H48S3R3	48	18 - 75	3.3	10	461	400	5500	25	100	3.9	82	10000 $\mu$ F
KMW25H48S5	48	18 - 75	5	10	613	350	5000	25	100	6.8	85	10000 $\mu$ F
KMW30H48S12	48	18 - 75	12	10	702	166	2500	25	100	15	89	1000 $\mu$ F
KMW30H48S15	48	18 - 75	15	10	702	133	2000	25	100	18	89	1000 $\mu$ F
KMW30H48D12	48	18 - 75	$\pm 12$	10	702	$\pm 83$	$\pm 1250$	25	100	$\pm 15$	89	330 $\mu$ F
KMW30H48D15	48	18 - 75	$\pm 15$	10	702	$\pm 65$	$\pm 1000$	25	100	$\pm 18$	89	330 $\mu$ F

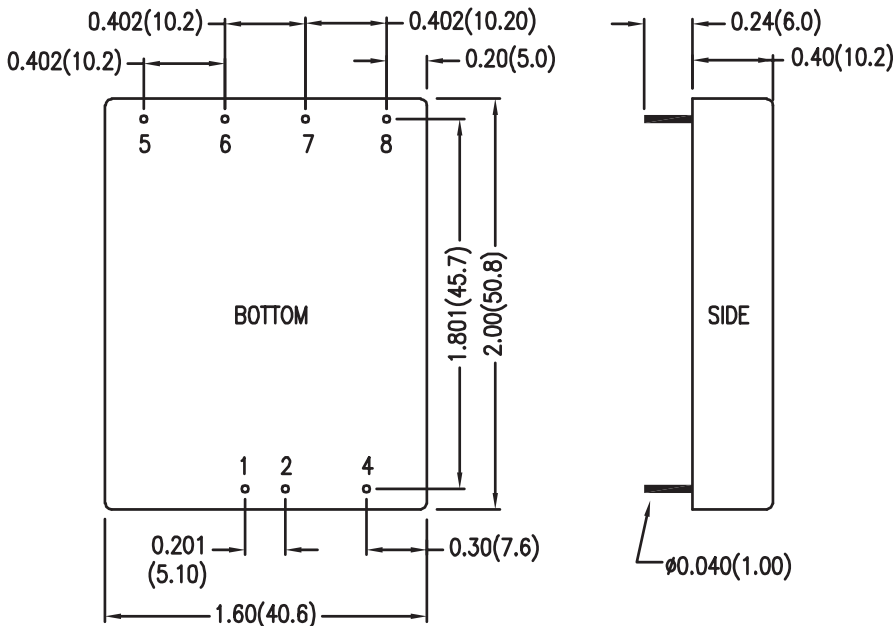

Pin Connections (NC) Not Connected		
Pin	Single	Dual
1	+Vin	+Vin
2	-Vin	-Vin
4	Remote On/Off	Remote On/Off
5	No Pin	+Vout
6	+Vout	Common
7	-Vout	-Vout
8	Trim	Trim

See Model Selection Table for Model Specific Parameters

Input Parameters	Min	Typ	Max	Units	
Reverse Polarity Input Current			2	A	
Short Circuit Input Power			4500	mW	
Start Voltage	24 Vin	9.4	9.7	10	VDC
	48 Vin	17	17.5	18	
Under Voltage Shutdown	24 Vin	9	9.3	9.5	VDC
	48 Vin	16	16.5	17	
Switching Frequency	290	330	360	kHz	
Input Filter	Pi Filter				
Output Parameters	Min	Typ	Max	Units	
Output Voltage Accuracy		±0.5	±1.0	%	
Output Voltage Balance Dual Output, Balanced Loads		±0.5	±2.0	%	
Load Regulation Io = 50% to 100%		±0.3	±1.0	%	
Line Regulation Vin=Min. to Max.		±0.2	±0.5	%	
Ripple & Noise (20MHz)		55	80	mV P-P	
Ripple & Noise (20 MHz) Over Line, Load & Temp			100	mV P-P	
Ripple & Noise (20 MHz)			10	mV RMS	
Over Power Protection	120		180	%	
Transient Recovery Time 25% Load Step Change		150	300	µs	
Transient Response Deviation, 25% Load Step Change		±2	±4	%	
Temperature Coefficient		±0.01	±0.02	% / °C	
Short Circuit Protection	Continuous				
General Specifications	Min	Typ	Max	Units	
Isolation Voltage, 60 seconds	1500			VDC	
Isolation Resistance 500VDC	1000			Mohms	
Isolation Capacitance, 100kHz, 1V		1200	1500	pF	
Operating Temperature (Ambient)	-40		+50	°C	
Storage Temperature	-50		+125	°C	
Humidity			95	%	
Over Temperature Protection (Case Temperature, automatic recovery)	107	112	117	°C	
MTBF MIL-HDBK-217F @25°C, Ground Benign	1000			K Hours	
Cooling	Free-Air Convection				
Case Size	2.0 x 1.6 x 0.40 inches 50.8 x 40.6 x 10.2 mm				
Case Material	Six-Sided Shielded, Metal Case (UL94V-0)				
Weight	48g				
Agency Approval	UL60950 Approved				

Input Fuse Selection Table	
24V Input	5000 mA Slow-Blow
48V Input	3000 mA Slow-Blow

External fusing should be used for system protection due to a catastrophic failure. See ConTech website for Fusing Application Notes to determine the correct fuse.

Remote On/Off	Min	Typ	Max	Units
Supply On	2.5 to 100VDC or Open Circuit			VDC
Supply Off	-1		1	VDC
Device Standby Input Current		2	5	mA
Control Input Current (on) Vin - RC = 5.0V			5	µA
Control Input Current (off) Vin - RC = 0V			-100	µA
<b>Control Common</b>	<b>Referenced to Negative Logic</b>			
Output Voltage Trim	Min	Typ	Max	Units
Trim Up / Down Range % of nominal output voltage	±9.0	±10.0	±11.0	%

Notes:

- Specifications typical at Ta=+25°C, resistive load, nominal input voltage, full rated output current unless otherwise noted.
- Transient recovery time is measured to within 1% error band for a step change in output load 75% to 100%.
- ConTech power converters require a minimum output loading to maintain specified regulation. Operation under no-load conditions will not damage these modules; however, they may not meet all specifications listed.
- The series has a limitation of a maximum connected capacitance at the output. The power module may be operated in current limiting mode during start-up, affecting the ramp-up and the startup time.
- When measuring peak-to-peak output noise, use a Cout 0.47µF ceramic capacitor. Scope measurement should be made by using a BNC socket, measurement bandwidth is 0-20MHz. Position the load between 2" and 2.5" from the converter.
- Water washability - ConTech DC/DC converters are designed to withstand most solder/wash processes. Careful attention should be used when assessing the applicability in your specific manufacturing process. Converters are not hermetically sealed.
- See ConTech website for Definition of Terms, Application Notes, and Test Setups and Parameters. [www.ConTech-us.com/appnotes.html](http://www.ConTech-us.com/appnotes.html)
- Specifications subject to change without notice.
- See ConTech website [www.ConTech-us.com/pdf/rohs.pdf](http://www.ConTech-us.com/pdf/rohs.pdf) for RoHS Statement.

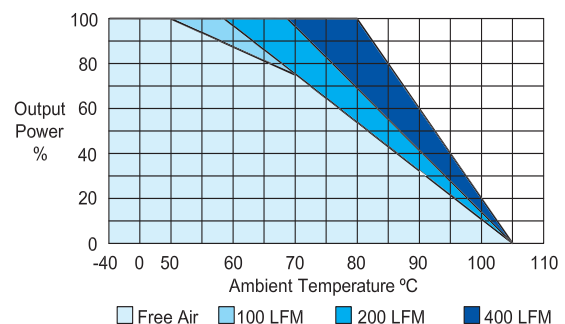

Derating Curve

To avoid exceeding the maximum temperature rating of the components inside the power module, the case temperature must be kept below 90°C.



# Block Diagrams

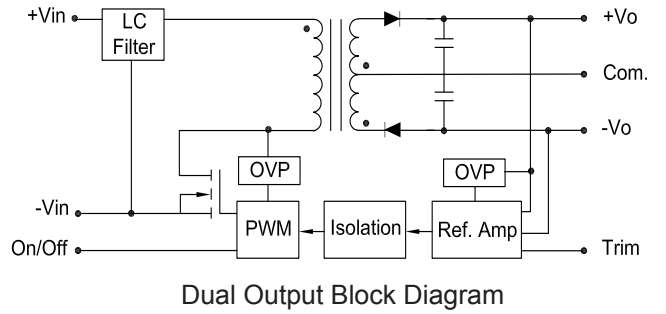
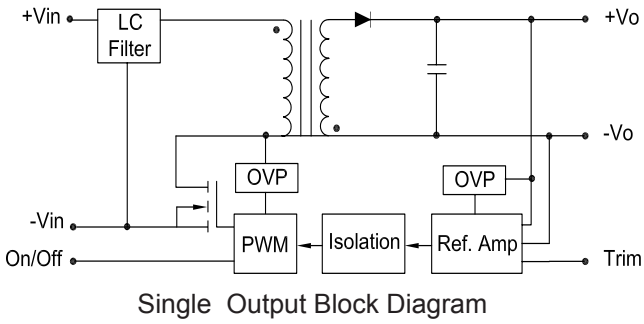

# Efficiency Curves

## Single Output

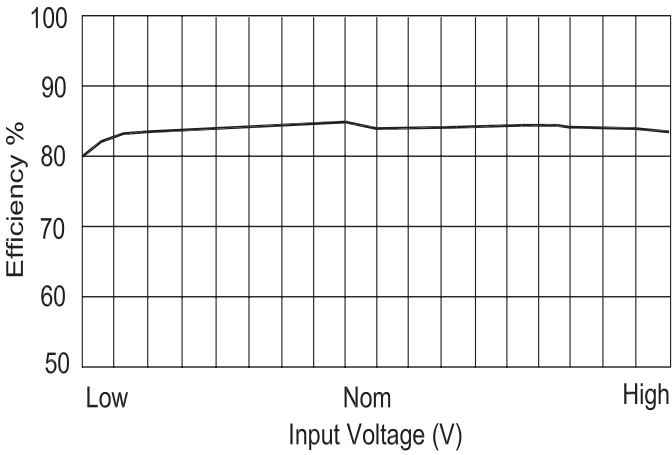

Efficiency vs Input Voltage

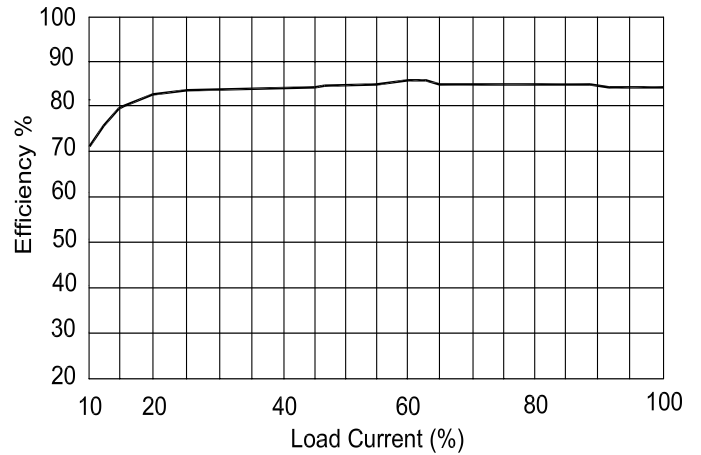

Efficiency vs Output Load

## Dual Output

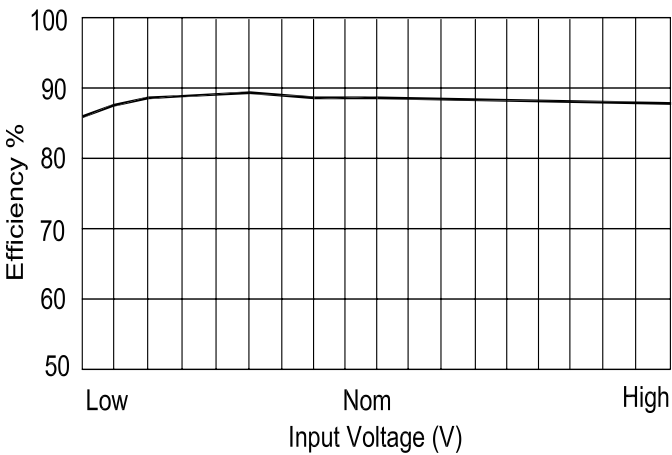

Efficiency vs Input Voltage

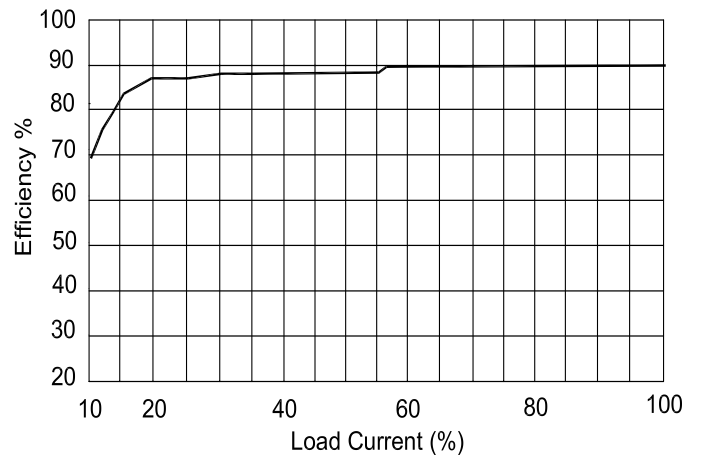

Efficiency vs Output Load