



25-30 Watt KMS Single and Dual Series



- Efficiency up to 89%
- 1500VDC Isolation
- MTBF > 1,000,000 Hours
- 2:1 Input
- Six-Sided Shielding
- Over Voltage Protection
- Remote On/Off
- Output Trim
- CSA Approved
- RoHS Compliant



Model Number	Voltage			Current				Reflected Ripple	Input Overvoltage (1000ms)	Over Voltage Protection	Efficiency	Capacitive Load
	Input		Output	Input		Output						
	Nom. (VDC)	Range (VDC)	(VDC)	@ No Load (mA)	@ Max Load (mA)	Min (mA)	Max (mA)					
KMS18H12S3R3	12	9-18	3.3	40	1867	400	5500	100	25	3.9	81	470 μ F
KMS25H12S5	12	9-18	5	40	2480	350	5000	100	25	6.8	84	470 μ F
KMS30H12S12	12	9-18	12	40	2841	166	2500	100	25	15	88	470 μ F
KMS30H12S15	12	9-18	15	40	2841	133	2000	100	25	18	88	470 μ F
KMS30H12D12	12	9-18	\pm 12	40	2841	\pm 83	\pm 1250	100	25	\pm 15	88	220 μ F
KMS30H12D15	12	9-18	\pm 15	40	2841	\pm 65	\pm 1000	100	25	\pm 18	88	220 μ F
KMS18H24S3R3	24	18-36	3.3	20	922	400	5500	50	50	3.9	82	470 μ F
KMS25H24S5	24	18-36	5	20	1225	350	5000	50	50	6.8	85	470 μ F
KMS30H24S12	24	18-36	12	20	1404	166	2500	50	50	15	89	470 μ F
KMS30H24S15	24	18-36	15	20	1404	133	2000	50	50	18	89	470 μ F
KMS30H24D12	24	18-36	\pm 12	20	1404	\pm 83	\pm 1250	50	50	\pm 15	89	220 μ F
KMS30H24D15	24	18-36	\pm 15	20	1404	\pm 65	\pm 1000	50	50	\pm 18	89	220 μ F
KMS18H48S3R3	48	36-75	3.3	10	461	400	5500	25	100	3.9	82	470 μ F
KMS25H48S5	48	36-75	5	10	613	350	5000	25	100	6.8	85	470 μ F
KMS30H48S12	48	36-75	12	10	702	166	2500	25	100	15	89	470 μ F
KMS30H48S15	48	36-75	15	10	702	133	2000	25	100	18	89	470 μ F
KMS30H48D12	48	36-75	\pm 12	10	702	\pm 83	\pm 1250	25	100	\pm 15	89	220 μ F
KMS30H48D15	48	36-75	\pm 15	10	702	\pm 65	\pm 1000	25	100	\pm 18	89	220 μ F

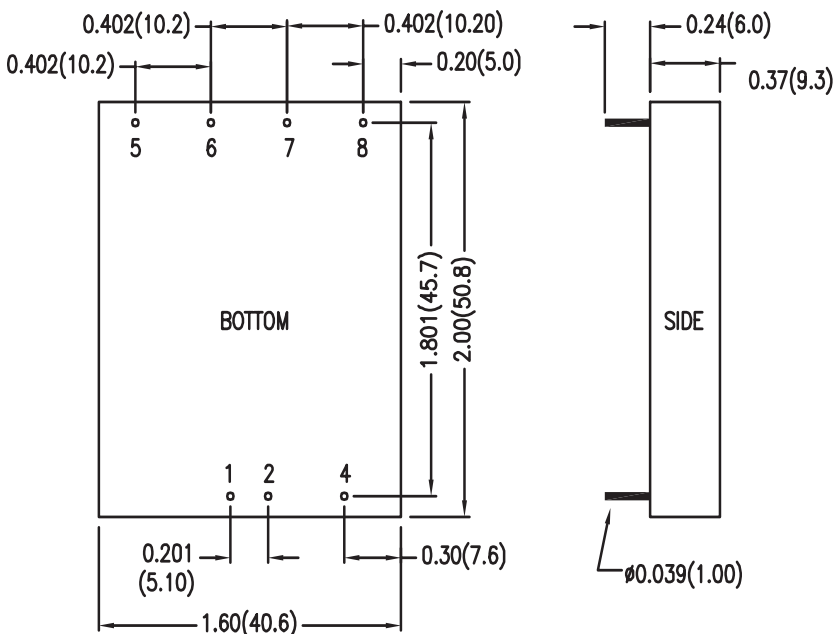

Dimensions are inches (mm) unless noted

Tolerance: Inches Millimeters
 X.XX \pm 0.02 X.X \pm 0.5
 X.XXX \pm 0.010 X.XX \pm 0.25
 Pin \pm 0.002 \pm 0.05

Pin Connections (NC) Not Connected		
Pin	Single	Dual
1	+Vin	+Vin
2	-Vin	-Vin
4	Remote On/Off	Remote On/Off
5	No Pin	+Vout
6	+Vout	Common
7	-Vout	-Vout
8	Trim	Trim

See Model Selection Table for Model Specific Parameters

Input Parameters	Min	Typ	Max	Units	
Reverse Polarity Input Current			2	A	
Short Circuit Input Power			4500	mW	
Start Voltage	12 Vin 24 Vin 48 Vin	8.6 17 34	8.8 17.5 35	9 18 36	VDC
Under Voltage Shutdown	12 Vin 24 Vin 48 Vin	8.1 16 32	8.3 16.5 33	8.5 17 34	VDC
Switching Frequency	290	330	360	kHz	
Input Filter	Pi Filter				
Output Parameters	Min	Typ	Max	Units	
Output Voltage Accuracy		±0.5	±1.0	%	
Output Voltage Balance Output, Balanced Loads	Dual	±0.5	±2.0	%	
Load Regulation I _o = 10% to 100%		±0.1	±0.5	%	
Line Regulation V _{in} =Min. to Max.		±0.1	±0.3	%	
Ripple & Noise (20MHz)		55	80	mV P-P	
Ripple & Noise (20 MHz) Over Line, Load & Temp			100	mV P-P	
Ripple & Noise (20 MHz)			10	mV RMS	
Over Power Protection	110		160	%	
Transient Recovery Time 25% Load Step Change		150	300	µs	
Transient Response Deviation, 25% Load Step Change		±2	±4	%	
Temperature Coefficient		±0.01	±0.02	% / °C	
Short Circuit Protection	Continuous				
General Specifications	Min	Typ	Max	Units	
Isolation Voltage, seconds	60	1500		VDC	
Isolation Resistance 500VDC	1000			Mohms	
Isolation Capacitance, 100kHz, 1V		1200	1500	pF	
Operating Temperature (Ambient)	-40		+50	°C	
Storage Temperature	-50		+125	°C	
Over Temperature Protection Case Temperature, automatic recovery	107	112	117	°C	
Humidity			95	%	
MTBF MIL-HDBK-217F @25°C, Ground Benign	1000			K Hours	
Cooling	Free-Air Convection				
Case Size	2.0 x 1.6 x 0.37 inches 50.8 x 40.6 x 9.3 mm				
Case Material	Six Sided Shielding Metal Case (UL94V-0)				
Weight	48g				
Agency Approval	CSA60950 Approved				

Remote On/Off	Min	Typ	Max	Units
Supply On	2.5 to 100VDC or Circuit		Open	VDC
Supply Off	-1		1	VDC
Device Standby Input Current		2	5	mA
Control Input Current (on) V _{in} - RC = 5.0V			5	µA
Control Input Current (off) V _{in} - RC = 0V			-100	µA
Control Common	Referenced to Negative Logic			

Output Voltage Trim	Min	Typ	Max	Units
Trim Up / Down Range % of nominal output voltage	±9.0	±10.0	±11.0	%

Notes:

- Specifications typical at Ta=+25°C, resistive load, nominal input voltage, full rated output current unless otherwise noted.
- Transient recovery time is measured to within 1% error band for a step change in output load 75% to 100%.
- ConTech power converters require a minimum output loading to maintain specified regulation. Operation under no-load conditions will not damage these modules; however, they may not meet all specifications listed.
- The series has a limitation of a maximum connected capacitance at the output. The power module may be operated in current limiting mode during start-up, affecting the ramp-up and the startup time.
- When measuring peak-to-peak output noise, use a Cout 1.0µF ceramic capacitor. Scope measurement should be made by using a BNC socket, measurement bandwidth is 0-20MHz. Position the load between 2" and 2.5" from the converter.
- Water washability - ConTech DC/DC converters are designed to withstand most solder/wash processes. Careful attention should be used when assessing the applicability in your specific manufacturing process. Converters are not hermetically sealed.
- See ConTech website for Definition of Terms, Application Notes, and Test Setups and Parameters. www.ConTech-us.com/appnotes.html
- Specifications subject to change without notice.
- See ConTech website www.ConTech-us.com/pdf/rohs.pdf for RoHS Statement.

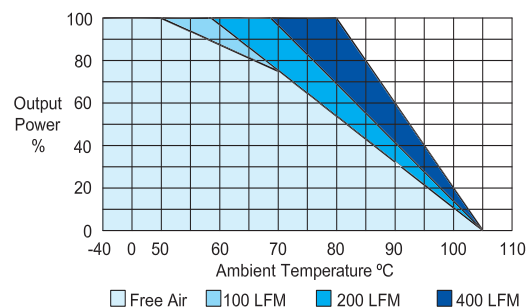

Derating Curve

To avoid exceeding the maximum temperature rating of the components inside the power module, the case temperature must be kept below 90°C.

Input Fuse Selection Table	
12V Input	6000 mA Slow-Blow
24V Input	3000 mA Slow-Blow
48V Input	1500 mA Slow-Blow

External fusing should be used for system protection due to a catastrophic failure. See ConTech website for Fusing Application Notes to determine the correct fuse.



Block Diagrams

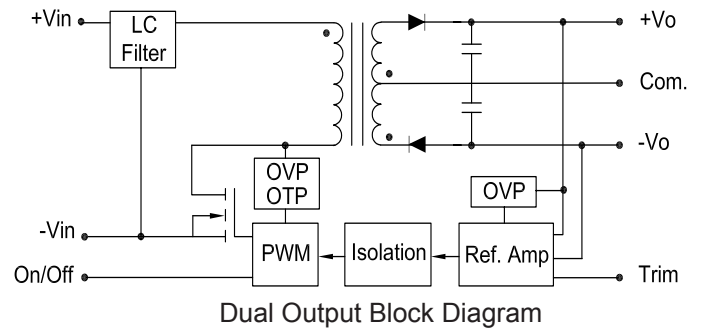
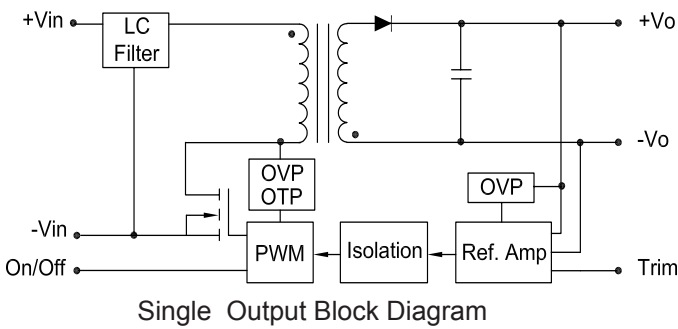

Efficiency Curves

Single Output

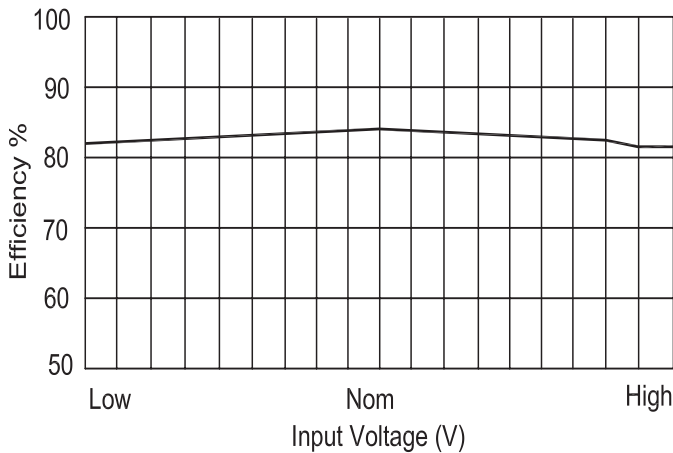

Efficiency vs Input Voltage

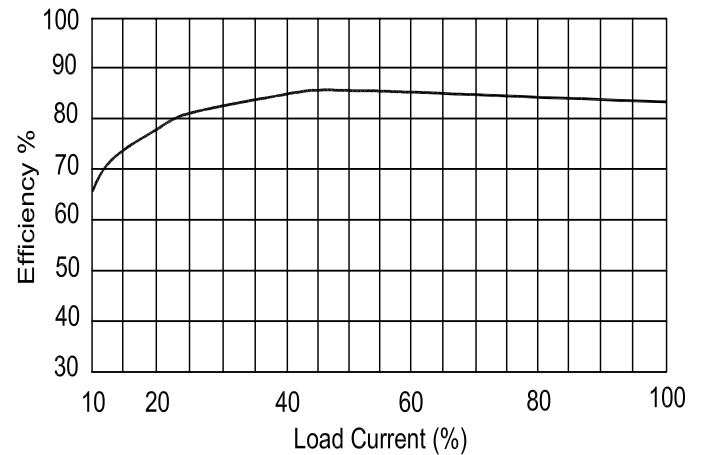

Efficiency vs Output Load

Dual Output

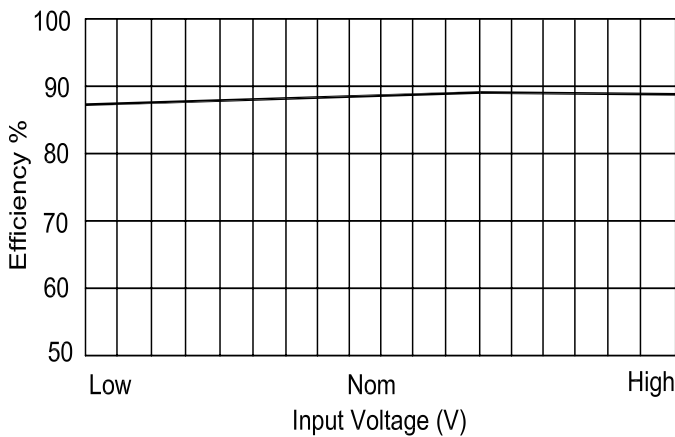

Efficiency vs Input Voltage

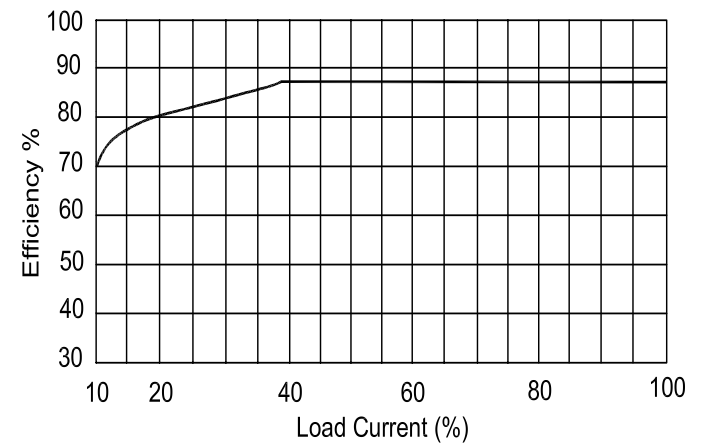

Efficiency vs Output Load