



40 Watt DRF Chassis Mount DC/DC Single Series

- Efficiency up to 92%
- 4:1 Input Range
- Fully Regulated Output Voltage
- 2500VDC Isolation
- Short Circuit Protection
- Over Voltage Protection
- Remote On/Off
- UL60950 Approved
- RoHS Compliant



Model Number	Voltage			Current			Efficiency @ Max Load (%, Typ)	Capacitive Load Max
	Input		Output	Input		Output		
	Nom. (VDC)	Range	(VDC)	@ No Load (mA)	@ Max Load (mA)	Max (mA)		
DRF40R24S5	24	9 - 36	5.1	90	1889	8000	90	13600 μ F
DRF40R24S12	24	9 - 36	12	90	1850	3300	90	2400 μ F
DRF40R24S24	24	9 - 36	24	90	1856	1670	90	600 μ F
DRF40R24S48	24	9 - 36	48	90	1876	835	89	150 μ F
DRF40R48S5	48	18 - 75	5.1	55	955	8000	89	13600 μ F
DRF40R48S12	48	18 - 75	12	55	915	3300	91	2400 μ F
DRF40R48S24	48	18 - 75	24	55	908	1670	92	600 μ F
DRF40R48S48	48	18 - 75	48	55	928	835	90	150 μ F

FOR DIN MOUNT ORDER OPTIONAL BRACKET DIN-02

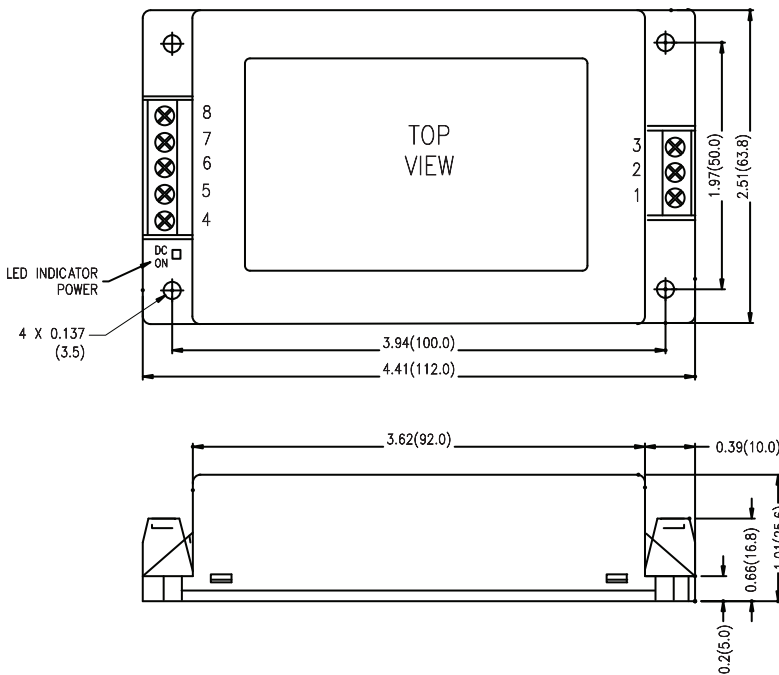

Dimensions are in inches(mm) unless noted
Tolerance: ± 0.02 (± 0.5)

Pin Connections (NC) Not Connected	
Pin	Function
1	Remote On/Off
2	-Vin
3	+Vin
4	+Vout
5	NC
6	-Vout
7	NC
8	NC

Input Parameters	Min	Typ	Max	Units
Input Surge Voltage 24 Vin 48 Vin	-0.7 -0.7		50 100	VDC
Start Voltage 24 Vin 48 Vin			9 18	VDC
Under Voltage Shutdown 24 Vin 48 Vin		7.5 16		VDC
Start Up Time Nominal Vin and Constant Resistive Load				
Power Up			30	ms
Remote On/Off			30	ms
Switching Frequency		285		kHz
Conducted EMI	Meets EN55002 Class A and FCC Part 15 Class A			
Input Filter	Pi Filter			
Output Parameters	Min	Typ	Max	Units
Output Voltage Accuracy		±2.0		% Vnom
Load Regulation Io = 0% to 100%		±1.0		%
Line Regulation Vin=Min. to Max.		±0.5		%
Minimum Load	No minimum load required			
Ripple & Noise (20MHz) 5.1 Vout 12 & 24 Vout 48 Vout			100 150 200	mV P-P
Transient Recovery Time 25% Load Step Change		250		µs
Transient Response Deviation, 25% Load Step Change		±3	±5	%
Temperature Coefficient		±0.02		% / °C
Over Voltage Protection Zener Diode Clamp		120		% of Vo
Over Load Protection (Hiccup)		150		%
Short Circuit Protection	Hiccup mode 0.25Hz typ. Auto Recovery			
General Specifications	Min	Typ	Max	Units
Isolation Voltage, 60 seconds	2500			VDC
Isolation Resistance 500VDC	1000			Mohms
Isolation Capacitance, 100kHz, 1V			2400	pF
Operating Temperature (Ambient)				
48S24	-40		+78	°C
48S12	-40		+76	
24S5, 24S12, 24S24, 48S48	-40		+73	
24S48, 48S5	-40		+71	
Storage Temperature	-50		+125	°C
Humidity			95	%
MTBF MIL-HDBK-217F @25°C, Ground Benign	>644			K Hours
Cooling	Natural Convection			
Case Size	4.41 x 2.51 x 1.01 inches 112.0 x 63.8 x 25.6 mm			
Case Material	Plastic resin (UL94V-0)			
Weight	162g			
Agency Approval	UL60950 Approved			

Remote On/Off	Min	Typ	Max	Units
Supply On	3.5 to 12V or Open Circuit			VDC
Supply Off	0 to 1.2V or Short Circuit			VDC
Device Standby Input Current Supply Off and Nominal Vin		3		mA
Control Input Current (On) Vctrl = 5.0V			0.5	mA
Control Input Current (Off) Vctrl = 0V			-0.5	mA
Control Common	Referenced to Negative Input			

Notes:

1. Specifications typical at Ta=+25°C, resistive load, nominal input voltage, full rated output current unless otherwise noted.
2. Transient recovery time is measured to within 1% error band for a step change in output load 75% to 100%.
3. ConTech power converters require a minimum output loading to maintain specified regulation. Operation under no-load conditions will not damage these modules; however, they may not meet all specifications listed.
4. The series has a limitation of a maximum connected capacitance at the output. The power module may be operated in current limiting mode during start-up, affecting the ramp-up and the startup time.
5. When measuring peak-to-peak output noise, use a Cout 0.47µF ceramic capacitor. Scope measurement should be made by using a BNC socket, measurement bandwidth is 0-20MHz. Position the load between 2" and 2.5" from the converter.
6. Water washability - ConTech DC/DC converters are designed to withstand most solder/wash processes. Careful attention should be used when assessing the applicability in your specific manufacturing process. Converters are not hermetically sealed.
7. See ConTech website for Definition of Terms, Application Notes, and Test Setups and Parameters. www.ConTech-us.com/appnotes.html.
8. Specifications subject to change without notice.
9. See ConTech website www.ConTech-us.com/pdf/rohs.pdf for RoHS Statement.

Derating Curves

40 Watt DRF

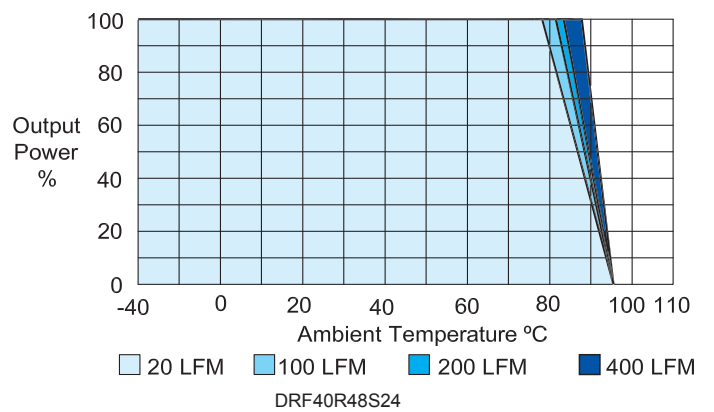
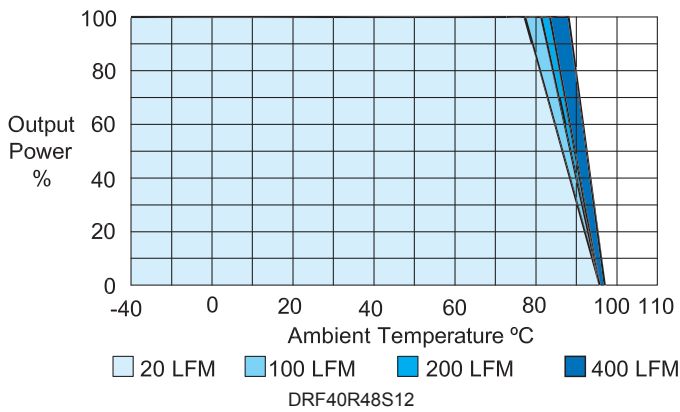
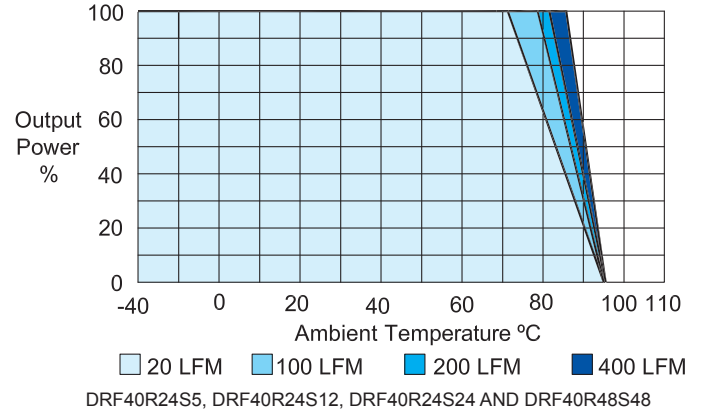
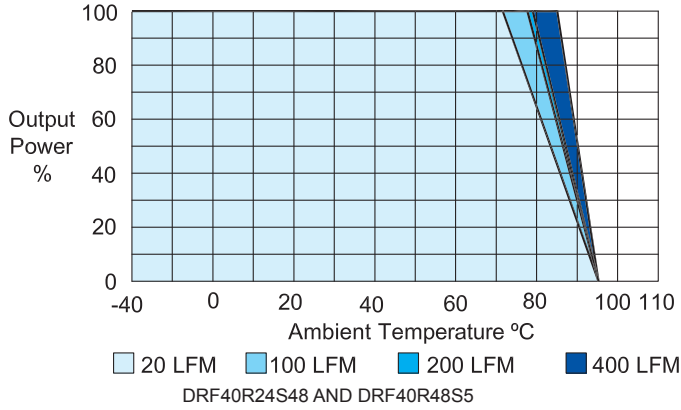

EMI

Conducted EMI	Meets EN55002 Class A and FCC Part 15 Class A
---------------	---

External components required to meet EN55022 Class A: FCC part 15

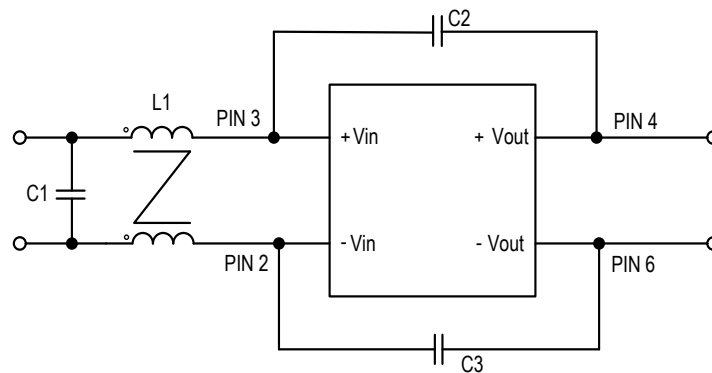

Model	L1	C1	C2	C3
DRF40R24SXX	175 μ H / 175 μ H	4.7 μ F 50V	220pF	220pF
DRF40R48SXX	175 μ H / 175 μ H	3.3 μ F 100V	220pF	220pF